

LUXMAN

High-Inertia, Belt-Driven, Arm-less Turntable with Vacuum Disc Stabilizer

PD 300

Features Our Exclusive Vacuum Disc Stabilizer.



LUX CORPORATION, JAPAN

VACUUM DISC STABILIZER

An Integration of Record Disc and Turntable Platter by Means of Vacuum Suction!! Total Banishment of Modulation Caused by Warp or Resonance of Record Disc.

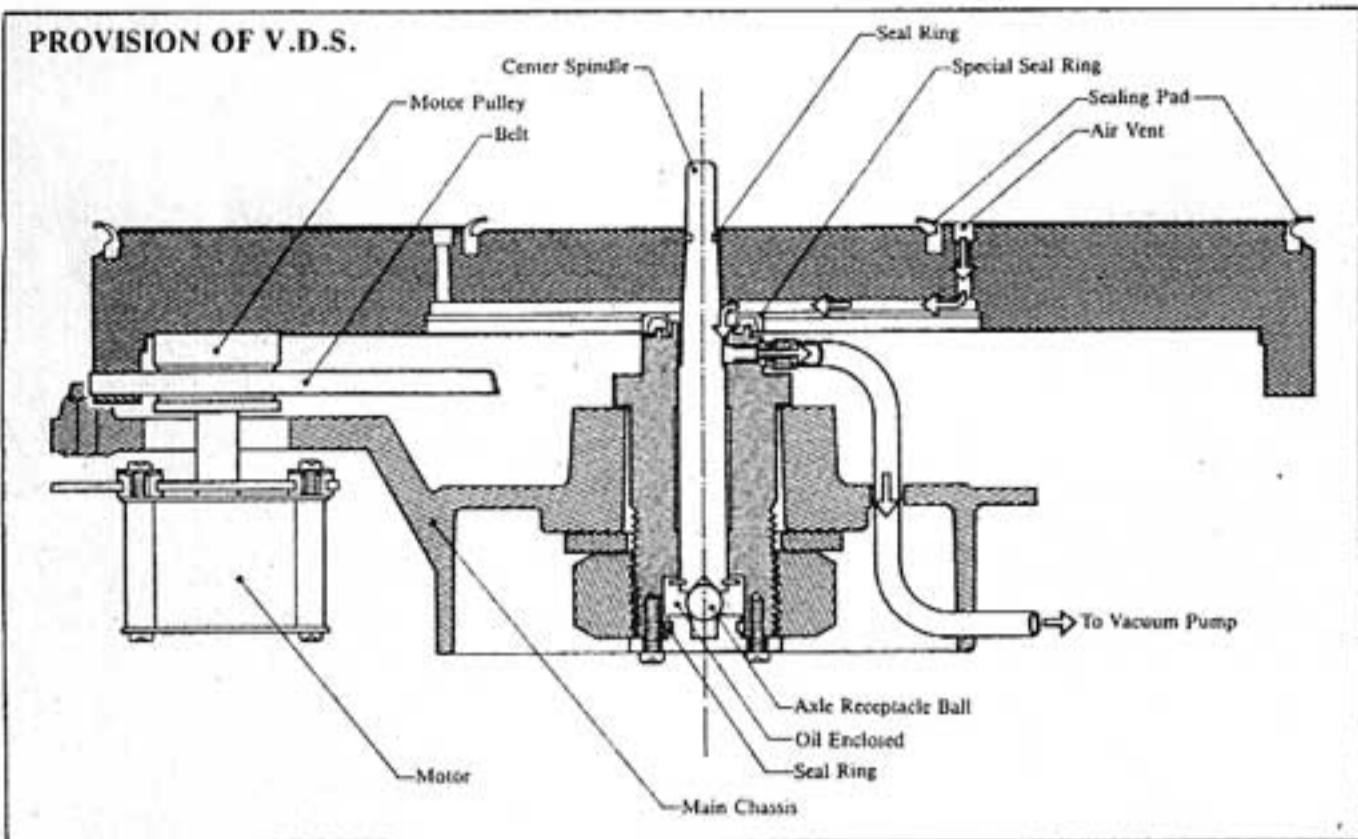

The playback method of record disc has been unchanged for all ages—simply to put a disc on the platter and then to place a pick-up on the disc. But this simple operation comprises various problems. Among others, what cannot be neglected in terms of sonic quality is self-resonance of the record disc. Such harmful additives not contained in the original signals have to be removed by all means for purest fidelity reproduction.

So far, many audiophiles have tried to make improvements in this respect utilizing so-called audio stabilizer of special platter mat. But no definite solution has been given to the problem of this noxious modulation triggered by a slight warp or resonance of the disc itself.

The V.D.S. system is to integrate the record disc and turntable platter, so to say, to make a record disc of high inertia. By removal of the air between the disc and platter, atmospheric pressure changes itself into a stabilizer, which works evenly throughout an entire surface of the disc. This is truly an ideal turntable system.

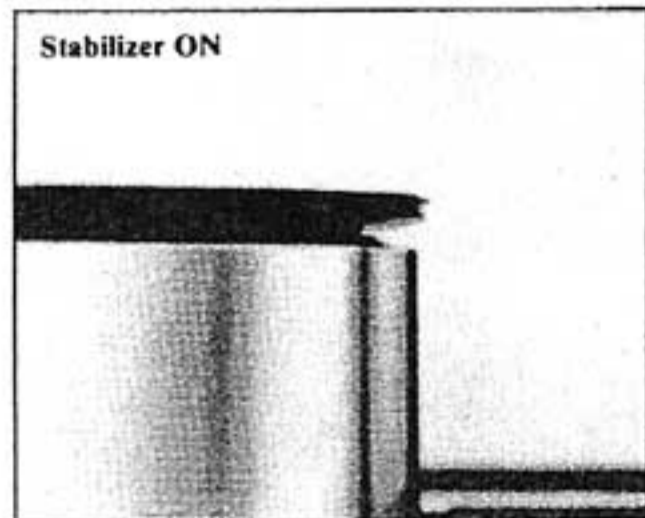
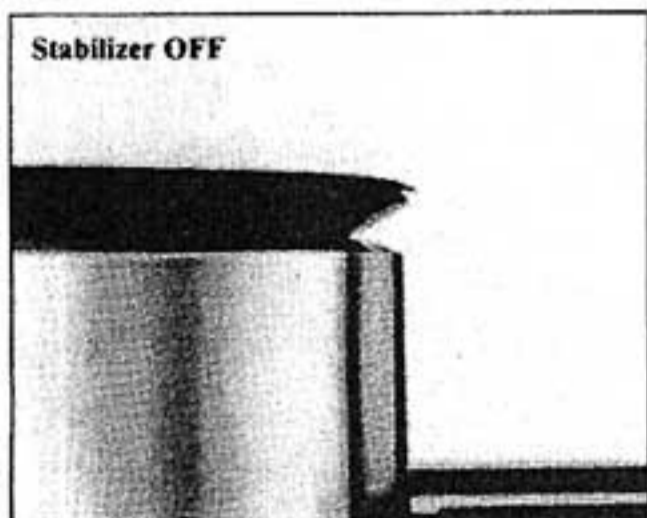

The PD300 is the first turntable incorporating the disc sucking system, where a vacuum pump of simple robust construction is employed with application of the theory of bellows. To suck out the air, grooves and sucking hole are provided on the surface of the platter, and the air passage inside the platter is connected to the pump by means of tube.

The pressure given to the sound grooves is equivalent to placement of 30kg stabilizer in terms of weight, and perfect stabilization effect is ensured.

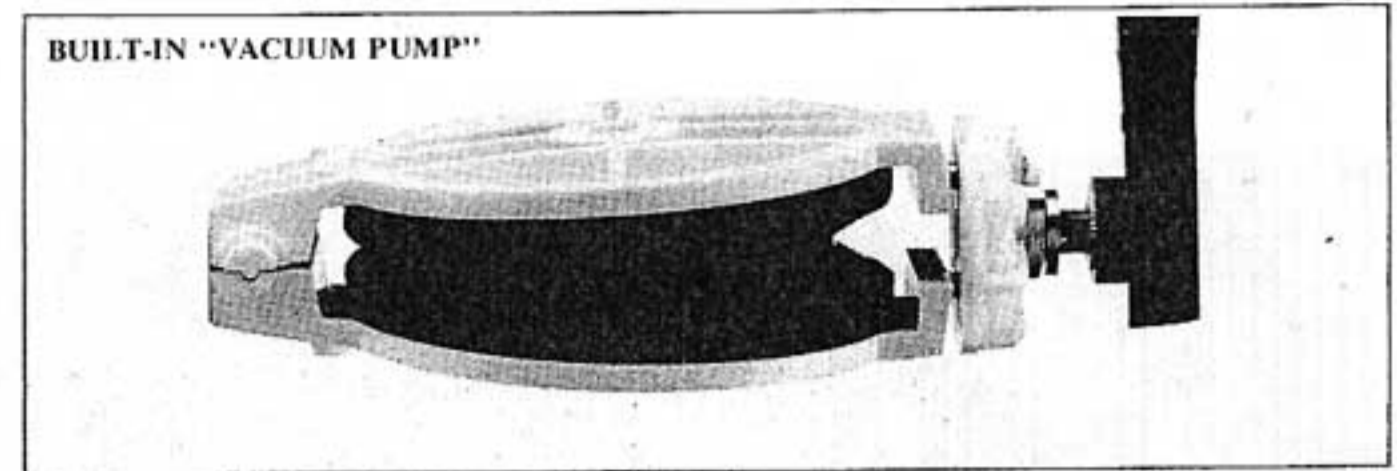

Suction and its release can be done by simple one-touch operation of the suction lever provided at the front of the cabinet, thus ensuring easy accessibility. Normally the lever is placed horizontally, and when it is turned upright, sucking function is activated. When the specified level of suction is reached, the indicator turns from orange to green. This indicator functions quite accurately by sensing the vacuum degree between the platter and disc.

The idea of the V.D.S. system came from the disc-cutting lathe. But the system employed at the lathe is to sustain the vacuum state by keeping sucking, which inevitably causes

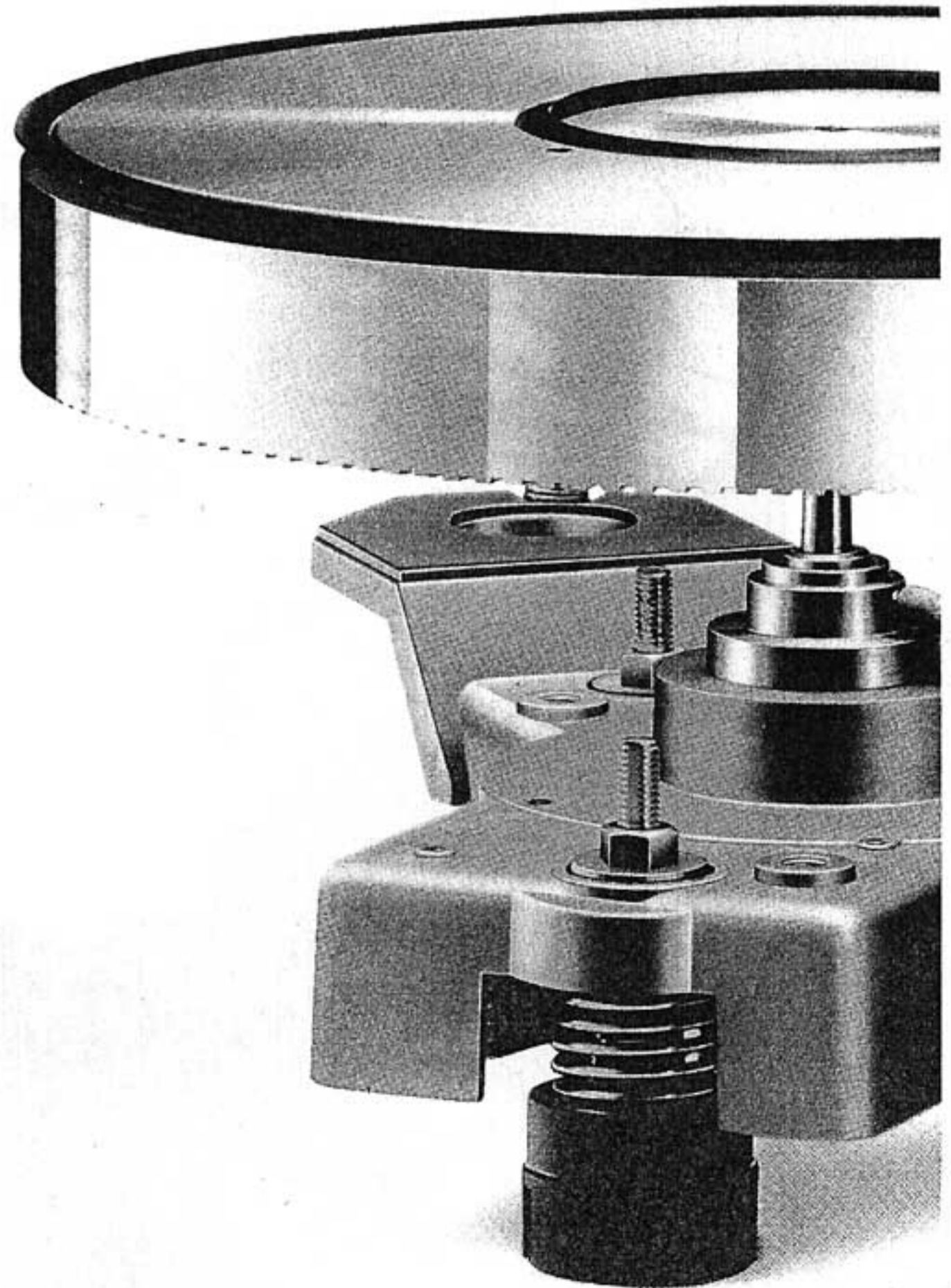

THE ULTIMATE IN BASIC PERFORMANCES—AND NOW

noises and vibrations. Therefore, with the PD300, to keep airtight the special sealing pads are placed on the surface of the platter positioning on the outer and inner rings of sound grooves of LP disc. Thanks to these pads, once sucked, the vacuum state can be sustained for long. The pad remains unchanged in quality for long time, but for eventual replacement it is so designed as to be easy in installation.

UNIFIED STRUCTURE

From Bearing Portion to Arm-base Fixing Portion to Remove Resonance. In Addition, Double Insulation System to Shut off External Vibrations.

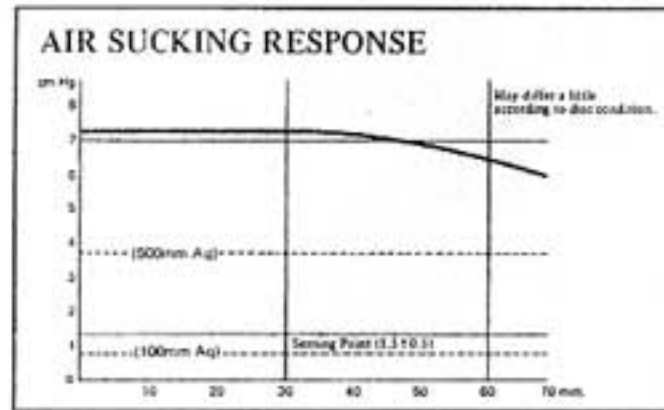
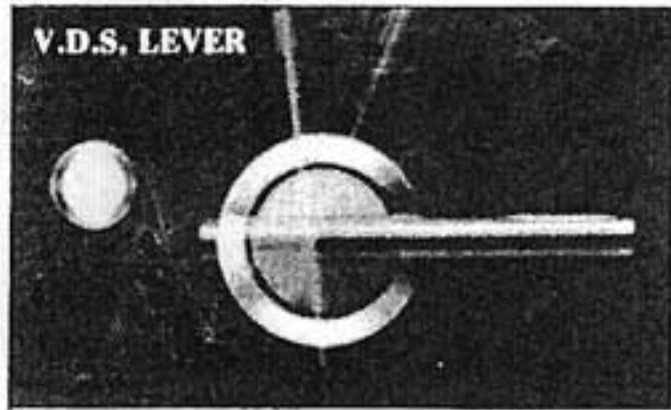

The object of the V.D.S. system is to remove harmful resonance from the turntable having perfect basic performances. Thus it is important to remove unnecessary vibrations in the rotation mechanism, not to speak of improvement in such fundamentals as S/N ratio, speed accuracy, etc. In this respect, the belt-drive system is used, and the motor is placed away from the orbit of the cartridge to evade influence of its flux and vibration.

The high-inertia platter having 3.5kg weight and 500kg/cm² inertia moment is driven by a high-performance, brushless, slotless DC servo motor that turns slowly at the ratio of 10 times as compared with that of the platter, which helps suppress vibration, and now totally noiseless rotation is realized by huge amount of energy thus obtained.

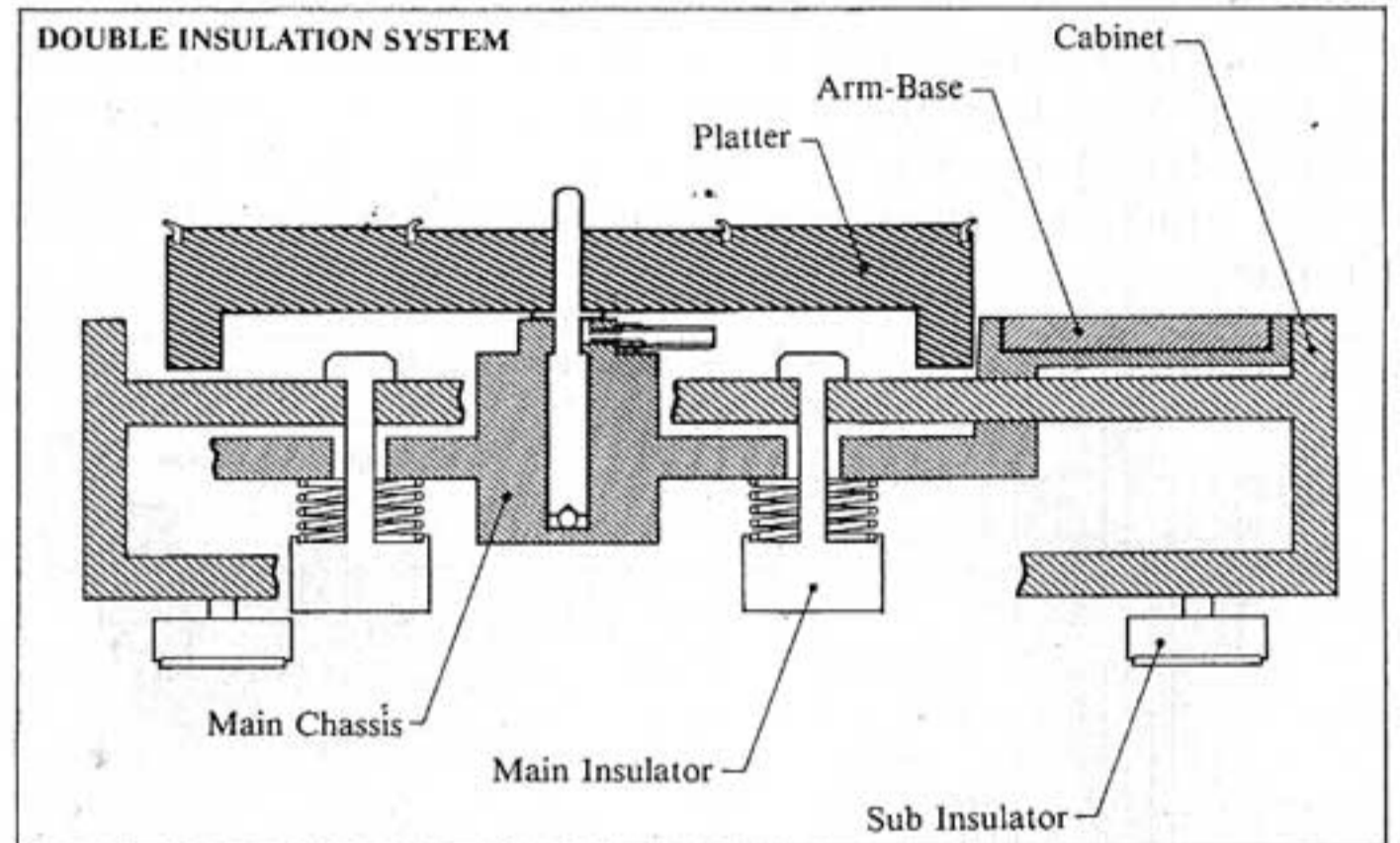

The ultimate style of turntable is that only the stylus tip vibrates on the solid base where all portions are integrated from the bearing to the tonearm. The PD300 is perfectly unified in this respect with provisions for interchangeability of tonearm. The unified main chassis of solid bearing and arm-base receptacle is made by die-casting of aluminum, to which a heavy arm-base is fixed by 6 bolts. Then put the platter and tonearm, and the sturdy-built frame of the PD300 is now completed. On top of the suction effect, thanks to this unified structure, all sources of undesired vibrations are eliminated from the playback loop, namely, record disc—turntable—tonearm. Brilliant birth is now given to truly "Non-Resonant" turntable system.

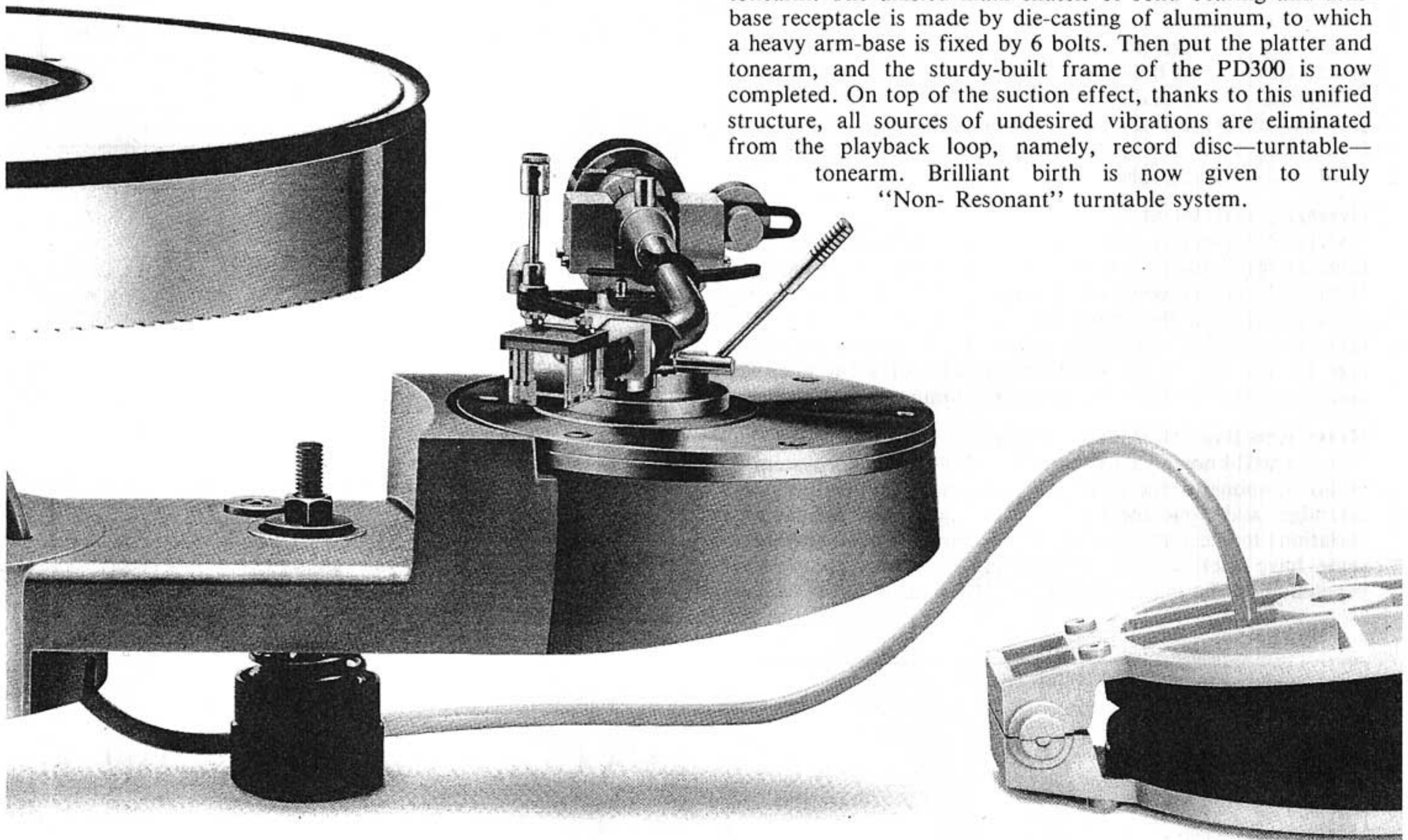

OUR EXCLUSIVE VACUUM DISC STABILIZER

Effective Insulator

Impeccable counter-measures are provided against external vibrations as well. One is the main insulator inserted between the main chassis and the heavy cabinet of solid structure, and the other is the large-sized sub-insulator provided at the legs of the cabinet. This double-insulation system safeguards the function of "non-resonant" body from external vibrations.

3 main insulators are placed on the main chassis, which hangs and damps the integrated playback block from the main cabinet. Here featured is LUX's exclusive 2-step damping insulator. The high-compliance natural rubber supporting the shaft cuts off the vibrations of small amplitude, while combination of spring and viscous brake of silicon grease effectively works against those of large amplitude. The horizontal balance of the platter can be adjusted by these insulators.

The large sub-insulators using natural rubber of good quality are provided at the 4 legs, which not only support the cabinet but damp the vibrations from the placement base. These insulators allow horizontal adjustment of the entire turntable.

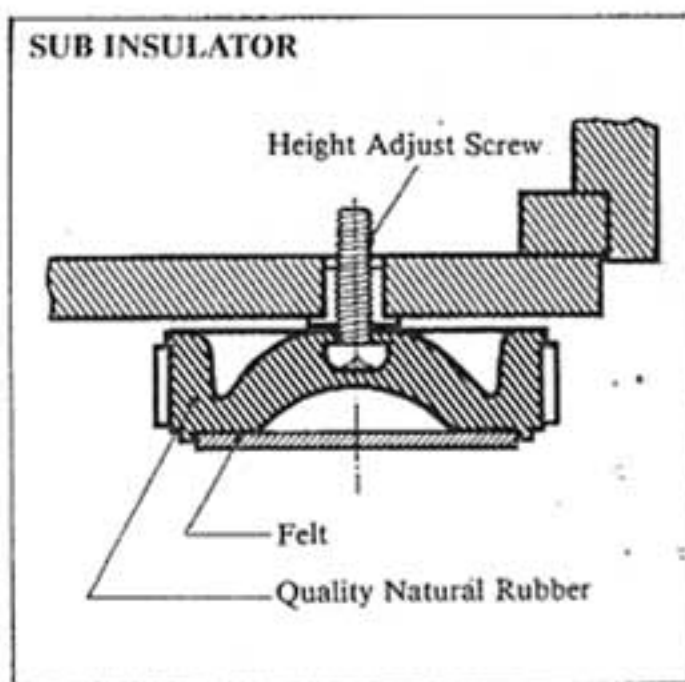
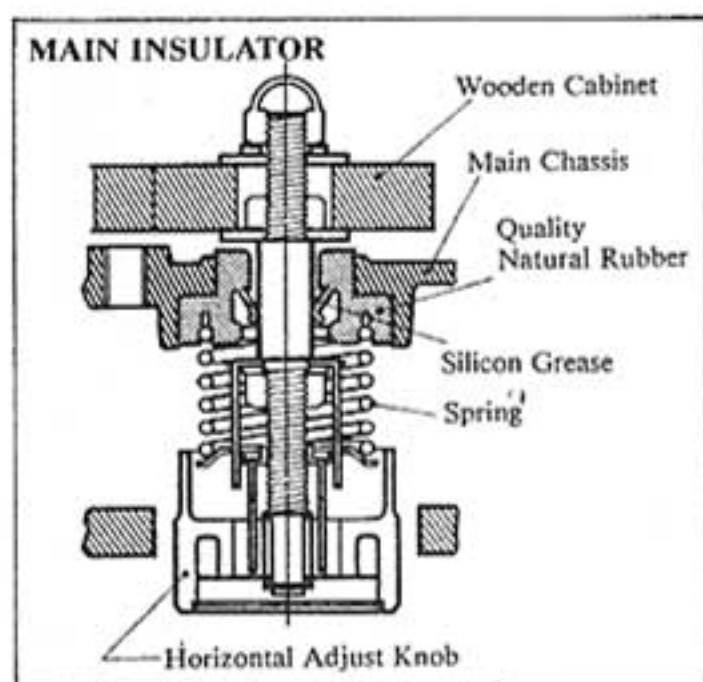

Abundant Accessories.

Fine Adjustment of Rotation

You can fine-tune the turning speed while monitoring the stroboscope placed beside the platter. Independent adjustment is possible for 33 and 45rpm formats by means of controls provided underneath the cabinet. The strobo pattern displayed by blinking light of crystal oscillator provides precise adjustment of the turning speed.

Overhang Adjustment

Generally speaking, the overhang adjustment requires much time, as the fixing screws of a cartridge have to be loosened. With this unit, the overhang can be easily adjusted by turning the arm-base, as the fixing hole of the arm-base for your tonearm is drilled out of its centre. Furthermore, the fixing hole for the bolt at the main chassis has sufficient tolerance and its subtle adjustment ensures the optimum overhang.

Heavy Arm-Base (Optionally Available)

It is a well-known fact that in the whole playback system of audio components the change at very input and output, i.e., cartridge and loud-speakers causes the most conspicuous variations to the tonal quality of playback sounds. Therefore, some have such wishes to interchange various components depending on the music sources, etc. Also many desire to have

special combination of their own at this input section of the turntable system according to their personal taste. To cater for such requirements of audiophiles the PD300 employs a detachable arm-base for easy replacement of tonearm. This heavy, feedback-resistant arm-base is made of planed aluminum plate having 8mm thickness which can be firmly fixed by 6 bolts. 4 different kinds are prepared for sale on option, and you can use most tonearms available in the marketplace.

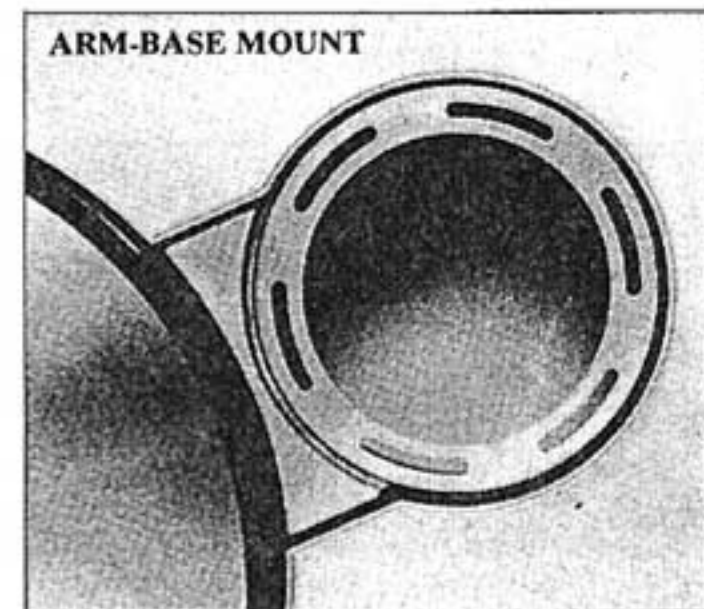
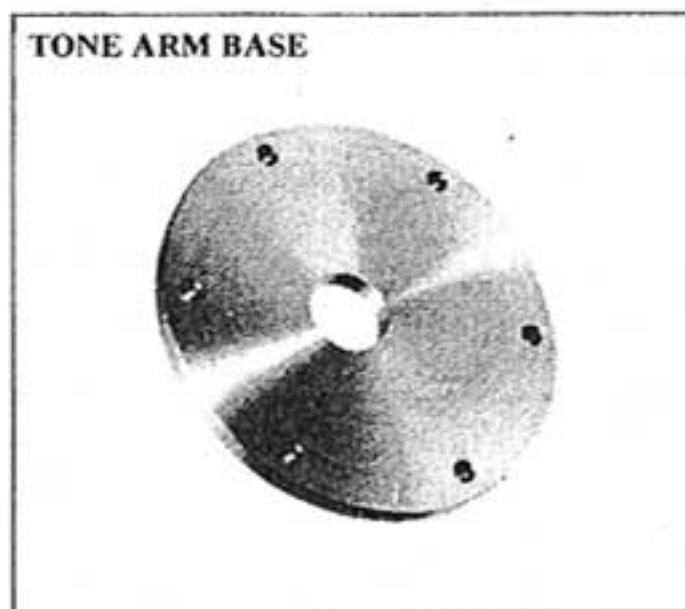

Tonearm Base & Applicable Tonearm

TYPE	BRAND	APPLICABLE TONEARM
TF-MT	LUXMAN STAX GRACE MICRO	TA-1 UA-7, UA-3, UA-9 G-704, G-714 MA-505, MA-707X, MA-303 MA-101mkII, MA-77mkII
	FR ORTOFON SAEC AUDIO TECHNICA	FR-64, FR-64S, FR-14 RMG-212" WE-308, WE-407/23 AT-1503III, AT-1100
TF-LH	VICTOR TECHNICS LUSTRE AUDIO CRAFT	UA7045 EPA-100 GST-801 AC-300mkII, AC-3000MC
	GRACE FR DENON AUDIO CRAFT EXEL SOUND ADC	G-940, G-545F, G-840F G-707, Σ-709, G-945 FR-54 DA-305, DA-307, DA-309 AC-3000, AC-300A ES-801 LMF-1, LMF-2
TF-LS	SME	3009SII, 3009SIII

PD300 SPECIFICATIONS

[PHONO MOTOR SECTION]

Driving System:	Belt Drive System
Motor:	Brushless & Slotless DC Servo Motor
Turntable Platter:	30cm (12") aluminum-cast, 3.5kgs (7.7 lbs.)
Inertia Moment:	500kg·cm ²
Rotation:	33-1/3 rpm, 45 rpm
Adjustable Range of Rotation:	±3% (33-1/3, 45 rpm independent)
Wow & Flutter:	no more than 0.03% (W.R.M.S.)
Signal-to-Noise Ratio:	better than 60dB (I.E.C.B.)
Run-up Time:	within 3 seconds (within 3/4 rotation for 33-1/3 rpm)

[ADDITIONAL FEATURES]

Vacuum Disc Stabilizer:	Manual Type
Stroboscope:	Illumination by built-in quartz oscillator
Acrylic Cover:	4mm-thick, detachable, 1.8kgs (4 lbs.)
Insulator:	Double Insulation System with Horizontal Balance Adjust Facility
Tonearm Base:	Detachable

[GENERAL]

Power Consumption:	15W
Dimensions:	490(W) × 390(D) × 200(H)mm (19.6" × 15.6" × 8")
Weight:	Net 18kgs (39.6 lbs.)

Specifications and appearance design subject to change without notice.

Downloaded from www.vinylengine.com

LUX CORPORATION, JAPAN

1-1, 1-CHOME, SHINSENRI-NISHIMACHI, TOYONAKA-SHI, OSAKA 565
PHONE: 06-834-0004 TELEX: 5287106 LUXELE J

AUTHORIZED DEALER

